

# 7SG26 Tau 500

Auto Reclose and Check Synchronisation

## Document Release History

This document is issue 2010/02. The list of revisions up to and including this issue is:

Pre release

2010/02	Document reformat due to rebrand

## Software Revision History

--	--	--

The copyright and other intellectual property rights in this document, and in any model or article produced from it (and including any registered or unregistered design rights) are the property of Siemens Protection Devices Limited. No part of this document shall be reproduced or modified or stored in another form, in any data retrieval system, without the permission of Siemens Protection Devices Limited, nor shall any model or article be reproduced from this document unless Siemens Protection Devices Limited consent.

While the information and guidance given in this document is believed to be correct, no liability shall be accepted for any loss or damage caused by any error or omission, whether such error or omission is the result of negligence or any other cause. Any and all such liability is disclaimed.

## Contents

1.	INTRODUCTION .....	3
2.	CONNECTION SPECIFICATION AND RELAY SETTINGS .....	3
2.1.	Recommended cable .....	3
2.2.	Connection Method .....	3
2.3.	Transmission Method.....	3
2.4.	Transmission Rate.....	3
2.5.	Line Idle Setting .....	3
2.6.	Parity Setting .....	4
2.7.	Address Setting.....	4
3.	MODEMS .....	4
3.1	Connecting a modem to the relay(s).....	4
3.2	Setting the Remote Modem .....	4
3.3	Connecting to the remote modem.....	5

## Figures

Figure 1 - Basic Communications Configuration.....	6
Figure 2 - Basic Communications Configuration (Remote).....	6
Figure 3 - Star Type Comms. Configuration (Multiplexer).....	7
Figure 4 - Data Concentrator Configuration .....	7
Figure 5 - Optical Ring Configuration .....	8
Figure 6 - Configuration using the Sigma 3 – Dual Port RS232 Device.....	8

## 1. INTRODUCTION

This document describes how to connect the IEC870-5-103 compliant communications interface to a control system or interrogating computer.

To access the interface the user will need appropriate software within the control system or on the interrogating computer (e.g. Reydisp Evolution).

## 2. CONNECTION SPECIFICATION AND RELAY SETTINGS

This section defines the connection medium as defined by IEC 870-5-103. Appendix A shows some typical communication connections.

### 2.1. Recommended cable

Selection of fibre optic cable is critical. Fibres should be terminated with 9mm SMA connectors.

The recommended type is 200µm Plastic Coated Silica (PCS). This will allow a maximum transmission distance of 100m between Argus relays. It will also be the maximum distance between the ring network and the fibre to RS232 converter.

Alternatively, 1mm polymer cable may be used to reduce cost. This will provide transmission distances of upto 43m between relays. Note that the distance from the transmit output of the RS232 / fibre optic converter to the receive input of the first Argus relay should be not more than 6m. The distance from the transmit output of the last Argus to the receive input of the converter may be upto 43m.

No other types of cable are suitable for use with Argus relays.

### 2.2. Connection Method

Reyrolle relays can be connected in either a Star or Ring fibre-optic communications network. If star connected then a passive fibre optic hub must be used. A lower cost option is the ring configuration where the Argus relays are 'daisy chained.' That is, the transmit output of the first relay is connected to the receive input of the second relay, and so on until the ring is complete.

Communication to the ring may be achieved either locally in the substation or remotely via the Public Switched Telephone Network (PSTN). If remote communication is desired, then additional modem equipment must be installed.

Reydisp Evolution is a PC based software package providing capability for both local and remote communication. It provides features such as download of disturbance and event records, upload of relay settings, real-time monitoring of measurands and remote control of plant.

### 2.3. Transmission Method

The transmission method is Half Duplex serial asynchronous transmission. In IEC 870-5-103 the line idle state is defined as Light ON. This can alternatively be selected as Light OFF in the Communications Interface menu of the relay if required for use with alternate hardware (See Section 2.5).

### 2.4. Transmission Rate

Rates of 19200, 9600, 4800, 2400, 1200, 600, 300, 150, 110 and 75 bits per second (BPS) are provided. Only 19200 and 9600 BPS are defined in IEC 870-5-103, the additional rates are provided for local or modem communications.

### 2.5. Line Idle Setting

The line idle setting can be set to be either ON or OFF and the setting must be compatible with the device connected to the relay. The IEC 870-5-103 standard defines a line idle state of Light On. If the device the relay is connected to does not have a compatible fibre-optic port then a suitable electrical to optical converter is required to connect it to a standard RS232C electrical interface. A suitable converter is the Sigma 4 type, which is available from Reyrolle Protection.

Alternative converters are the Reyrolle Dual RS232 Port (Sigma 3) or Reyrolle Passive Fibre-Optic Hub (Sigma 1).

1. The Sigma 3 Dual RS232 port provides a fibre-optic interface to a relay and two RS232 ports. The RS232 system port is typically connected to a control system while the second port is a local port. When the local port is in use the system port is automatically disabled. The Sigma 3 has an

internal link to switch between line idle Light ON or Light OFF. The default configuration is Light OFF.

2. The Sigma 1 Passive Fibre-Optic Hub provides fibre-optic interfaces for up to 29 relays. It has a fibre-optic port to the control system and multiple relay connections. Each of the 30 fibre-optic ports can be configured for either Light ON or Light OFF operation. Default for all is OFF.

## 2.6. Parity Setting

IEC 870-5-103 defines the method of transmission as using EVEN Parity. However, in some instances an alternative may be required. This option allows the parity to be set to NONE.

## 2.7. Address Setting

The address of the relay must be set to a value between 1 and 254 inclusive before any communication can take place. Setting the address to zero disables communications to the relay, although if it is in an optical ring it will still obey the Data Echo setting. All relays in an optical ring must have a unique address. Address 255 is reserved as a global broadcast address.

## 3. MODEMS

The communications interface has been designed to allow data transfer via modems. However, IEC 870-5-103 defines the data transfer protocol as an 11 bit format of 1 start, 1 stop, 8 data and 1 parity bit which is a mode most commercial modems do not support. High performance modems, for example, Sonix (now 3Com), Volante and MultiTech Systems MT series will support this mode but are expensive. For this reason a parity setting (see section 2.6) to allow use of easily available and relatively inexpensive commercial modems has been provided. The downside to using no parity is that the data security will be reduced slightly and the system will not be compatible with true IEC870 control systems.

### 3.1 Connecting a modem to the relay(s)

The RS232C standard defines devices as being either Data Terminal Equipment (DTE) e.g. computers, or Data Communications Equipment (DCE) e.g. modems. To connect the modem to a relay requires a fibre-optic to electrical connector and a Null Terminal connector which switches various control lines. The fibre-optic converter is then connected to the relay in the following manner :

Fibre-Optic Converter	Relay Connections
<b>Tx</b>	<b>Rx</b>
<b>Rx</b>	<b>Tx</b>

### 3.2 Setting the Remote Modem

Most modems support the basic Hayes 'AT' command format, though, different manufacturers can use different commands for the same functions. In addition, some modems use DIP switches to set parameters while others are entirely software configured. Before applying the following settings it is necessary to return the modem to its factory default settings to ensure that it is in a known state.

The remote modem must be configured as Auto Answer, which will allow it to initiate communications with the relays. Auto answer usually requires 2 parameters to be set. One switches auto answer on and the other, the number of rings after which it will answer. The Data Terminal Ready (DTR) settings should be forced on which tells the modem that the device connected to it is ready to receive data. The parameters of the modem's RS232C port need to be set to match those set on the relay i.e. baud rate and parity to be the same as the settings on the relay, and number of data bits to be 8 and stop bits 1.

Since the modem needs to be transparent, simply passing on the data sent from the controller to the device and vice versa, the error correction and buffering must be turned off. In addition if possible force the Data Carrier Detect (DCD) setting to ON as this control line will be used by the fibre-optic converter.

Finally these settings should be stored in the modem's memory for power on defaults.

### **3.3 Connecting to the remote modem**

Once the remote modem is configured correctly it should be possible to dial into it using the standard configuration from a local PC. As the settings on the remote modem are fixed, the local modem should negotiate with it on connecting and choose suitable matching settings. If it does not, set the local modem to mimic the settings of the remote modem described above.

## APPENDIX A - COMMUNICATION CONNECTIONS

Figures 1 to 6 illustrate a number of methods of connecting relays in communications networks.

(Note that in the case of the optical ring configuration (figure 5), the Data Echo feature must be switched ON in the communications settings menu of the relay. In all other cases this setting should be set to OFF).

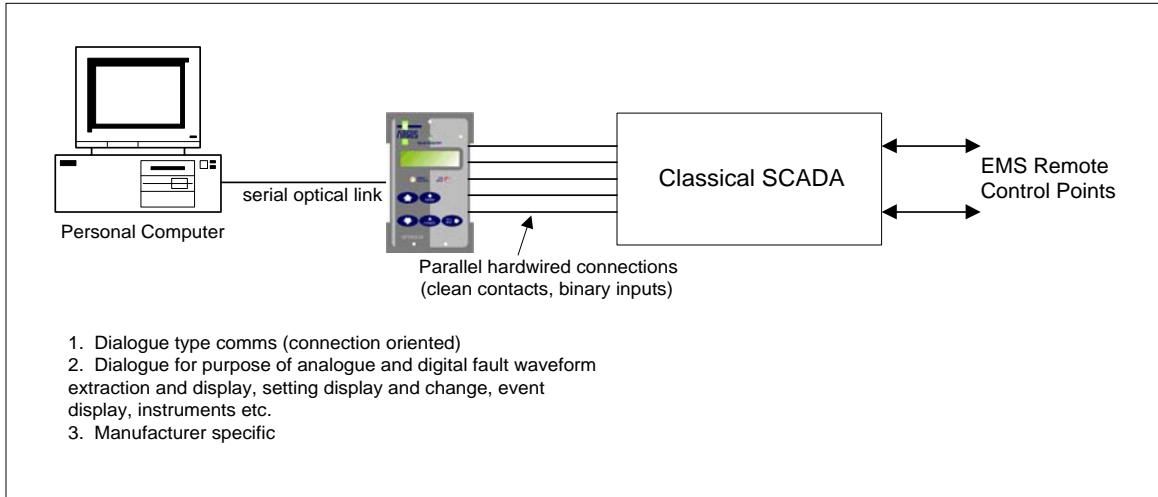

**Figure 1 - Basic Communications Configuration**

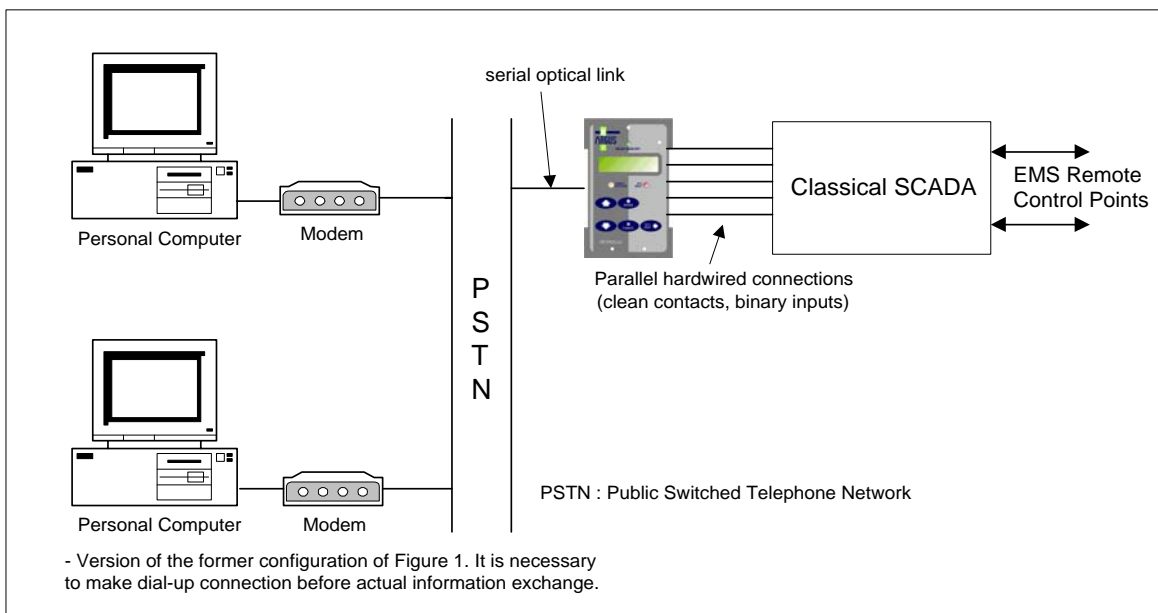

**Figure 2 - Basic Communications Configuration (Remote)**

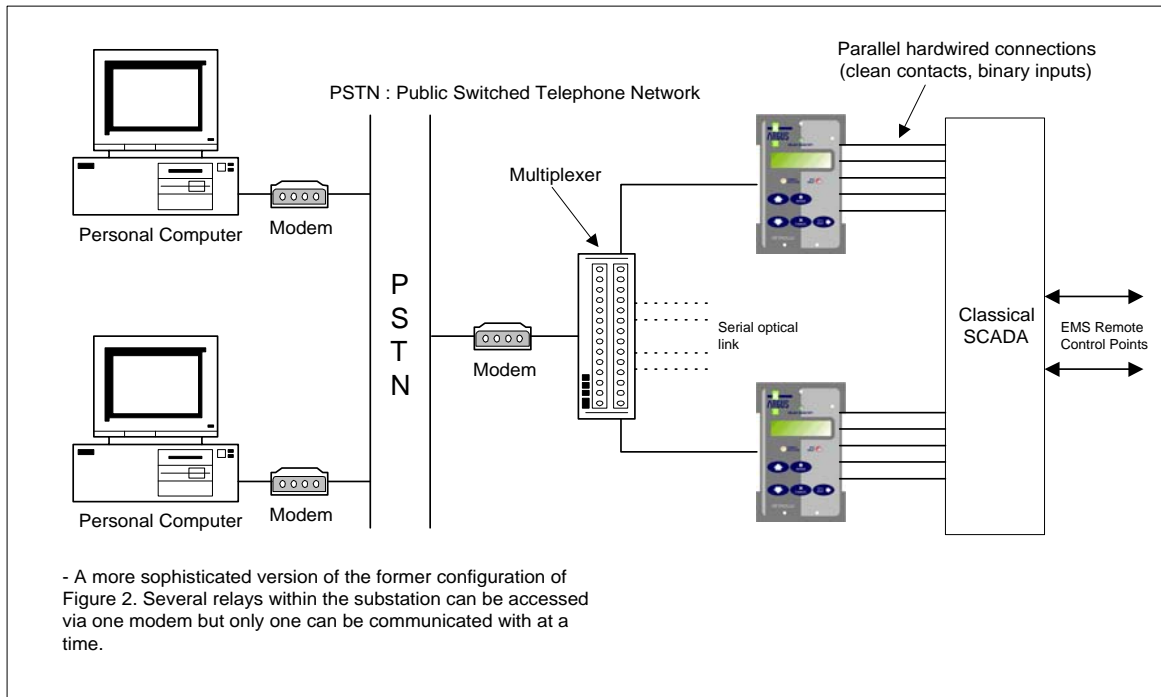

Figure 3 - Star Type Comms. Configuration (Multiplexer)

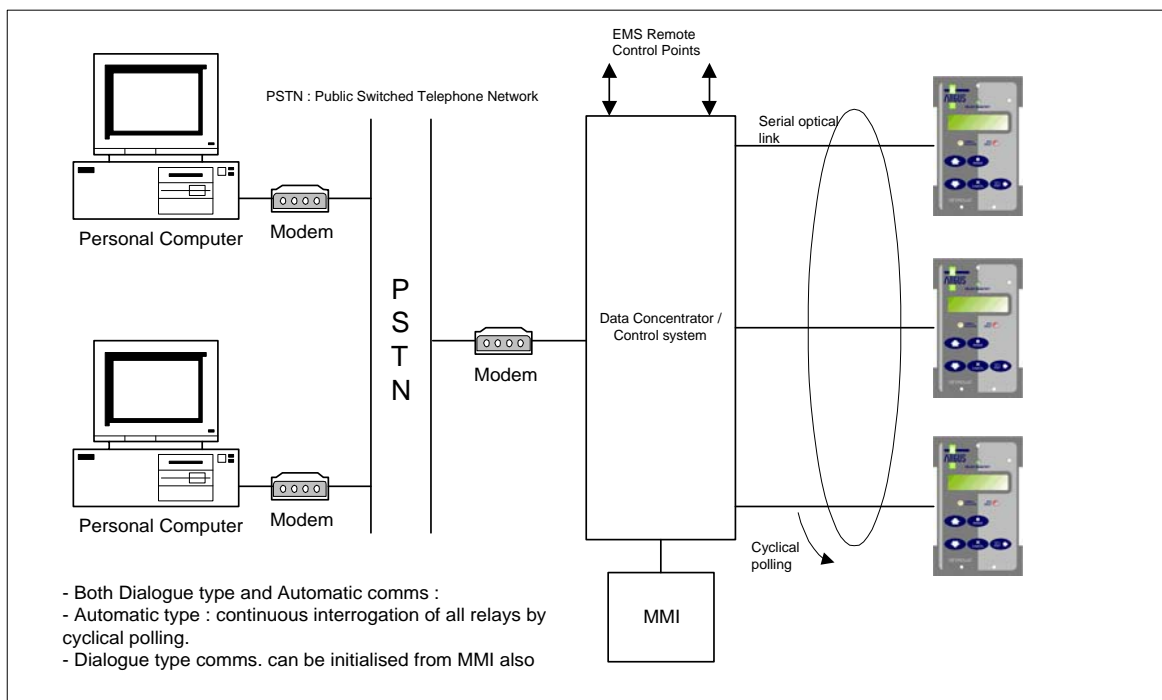

Figure 4 - Data Concentrator Configuration

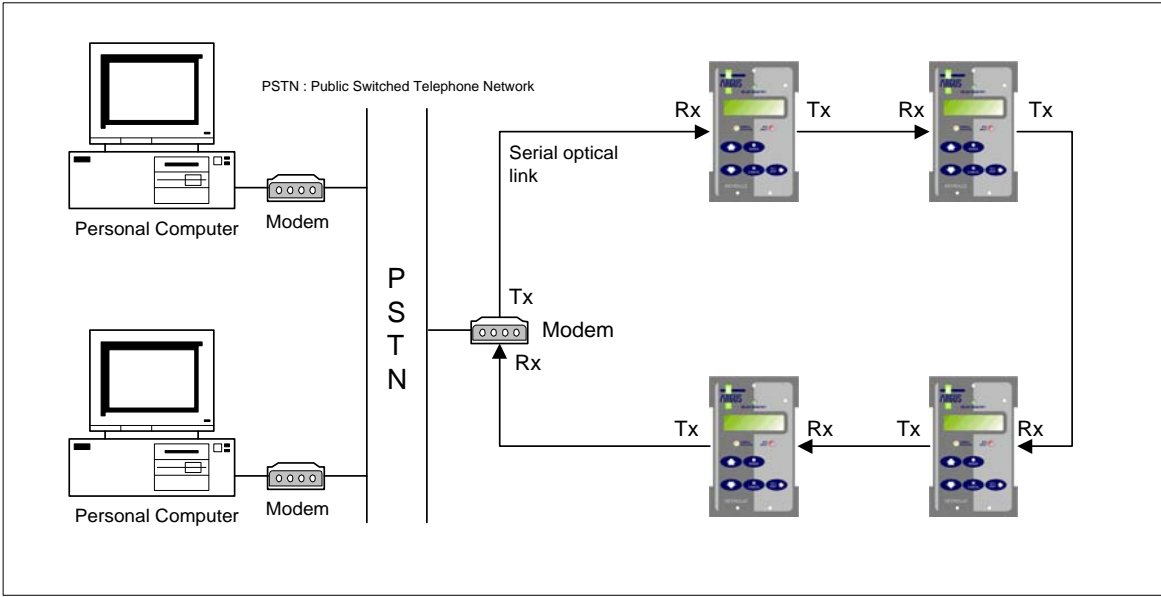

Figure 5 - Optical Ring Configuration

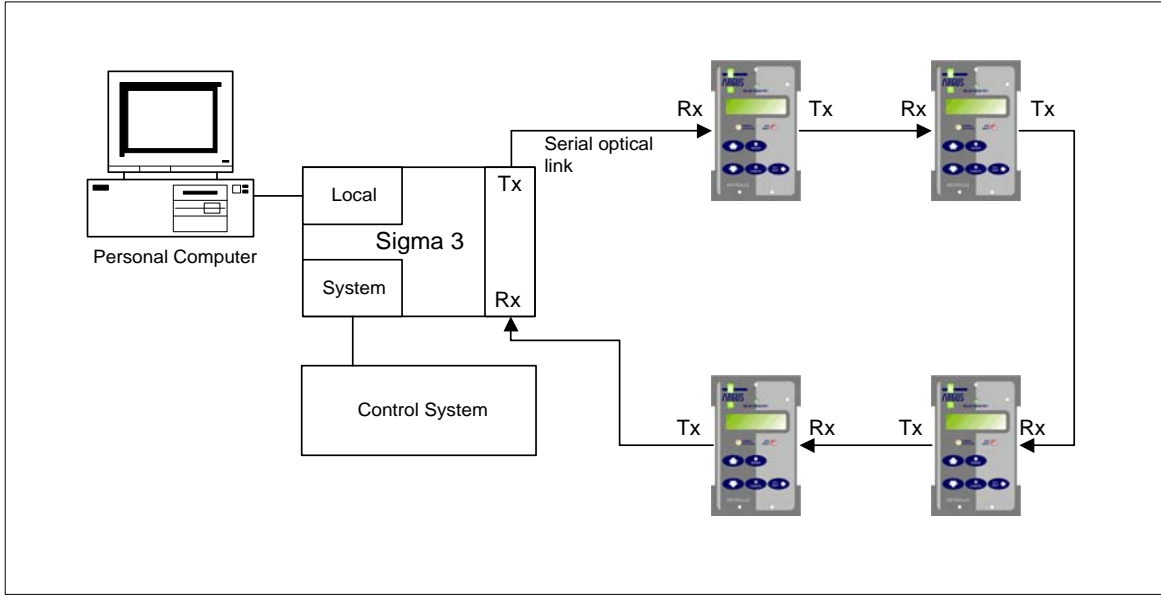

Figure 6 - Configuration using the Sigma 3 – Dual Port RS232 Device